



**VAL AVIONICS LTD**

# **AP 100 AUDIO PANEL**



Audio Management System

# **Installation and Operator's Manual**

Original Issue  
October 06

P/N 0720100

Val Avionics Ltd  
AP 100 Audio Panel  
Installation and Operator's Manual

Table of Contents

	Pg
1 SECTION I - GENERAL INFORMATION .....	1
1.1 INTRODUCTION .....	1
1.2 SCOPE .....	1
1.3 EQUIPMENT DESCRIPTION .....	1
1.4 SPECIFICATIONS.....	2
1.5 EQUIPMENT SUPPLIED.....	3
1.6 EQUIPMENT REQUIRED BUT NOT SUPPLIED .....	3
1.7 LICENSE REQUIREMENTS .....	3
2 SECTION II - INSTALLATION.....	4
2.1 GENERAL INFORMATION.....	4
2.1.1 Scope.....	4
2.2 UNPACKING AND INSPECTION.....	4
2.3 EQUIPMENT INSTALLATION PROCEDURES .....	4
2.3.1 Cooling Requirements .....	4
2.3.2 Mounting Requirements.....	5
2.3.3 Wire Harness Fabrication .....	5
2.3.4 Audio Panel Installation.....	5
2.4 POST INSTALLATION CHECK .....	6
2.4.1 Operational Check .....	6
2.4.2 Final Inspection.....	6
2.5 LIMITATIONS.....	7
3 SECTION III - OPERATION.....	8
3.1 GENERAL INFORMATION.....	8
3.1.1 Scope.....	8
3.1.2 Transmit Selection .....	8
3.1.3 Audio Selection.....	8
4 SECTION IV - WARRANTY AND SERVICE.....	10
4.1 WARRANTY .....	10
4.2 SERVICE.....	11
5 Appendix A – INSTALLATION DRAWINGS AND CONNECTOR LAYOUT .....	12
6 Appendix B – WIRING DIAGRAMS.....	13
7 Appendix C – INSTRUCTIONS FOR CONTINUED AIRWORTHINESS .....	15
7.1 MAINTENANCE INSTRUCTIONS .....	15

Table of Figures

Figure 1 Unit Controls .....	8
Figure 2 Unit Controls .....	9
Figure 3 Physical Dimensions .....	12
Figure 4 Panel Cut Out .....	12

Val Avionics Ltd  
AP 100 Audio Panel  
Installation and Operator's Manual

Table of Tables

	Pg
Table 1 Specifications.....	2
Table 2 Equipment Supplied.....	3
Table 3 Equipment Not Supplied.....	3

Revision History

Rev.	Date	Description of change
IR	September 2006	Initial Release

# **1 SECTION I - GENERAL INFORMATION**

## **1.1 INTRODUCTION**

Ease of installation and simple operation make the AP 100 *Audio Management System* the communication solution for a wide variety of aircraft panels, from the Homebuilt through heavy twins. The AP 100 satisfies the need for convenience of a fully functioning quality Audio panel that can be counted on to provide years of reliable service.

Before installing and /or using your new AP 100 Audio Panel please read this manual completely. This will ensure proper installation and familiarize you with all of the features your new audio panel has to offer.

## **1.2 SCOPE**

This manual will provide detailed information about the installation and operation of the AP 100 Audio Panel. It will also provide equipment limitation information and instructions for continued airworthiness.

## **1.3 EQUIPMENT DESCRIPTION**

The AP 100 has been designed for simplicity. It is straight forward to install and operate. Using state of the art technology Val Avionics has created an Audio Panel that will provide the pilot with simple unencumbered control of the various audio sources commonly found in today's civil aircraft.

The COM 1 / COM 2 XMT SEL switches make it easy to select a transceiver for transmitting and receiving radio communications. The selected transceiver is indicated by an illuminated LED. This LED flashes while the transmit key is depressed. Received audio from the selected transceiver is automatically switched to the headphones. Received audio from both COM 1 and COM 2 can be routed to the headphones as desired by activating the BOTH switch. When both audios are selected an LED annunciation will illuminate.

NAV 1 and NAV 2 audios can be switched to the headphone using the NAV 1 and NAV 2 selector switching. These selections are also indicated by LED annunciation. All of the selected audios can be switched to the cabin speaker with the SPKR select switch. An LED annunciation will indicate this selection.

Val Avionics Ltd  
 AP 100 Audio Panel  
 Installation and Operator's Manual

Muting for the external marker beacon receiver audio is provided by the MKR switch. A steady LED annunciator for the MKR switch indicates that marker beacon received audio, if present, will be heard in the headphones and over the cabin speaker if the SPKR switch is selected. The pilot may mute the marker audio by depressing the MKR select switch. Doing so will mute the incoming marker audio for approximately 20 seconds. While the marker audio is muted the MKR LED annunciator will flash.

Four un-switched audio inputs are provided at the rear connector for such audio inputs as DME, ADF, Auto Pilot alerts or any other audio source which would commonly be routed to the aircraft headphone and cabin speaker systems.

A Fail-safe feature has been incorporated into the design of the AP 100 that will automatically connect the pilot's headphones and microphone to the aircrafts COM 1 radio in the event that power is removed from the audio Panel or if the unit is powered down.

## 1.4 SPECIFICATIONS

**Table 1 Specifications**

<b>DIMENSIONS</b>	
Hight	1.0 in. (2.54 cm)
Width	6.34 in (16.10 cm)
Depth	5.83 in (14.81 cm) behind the panel
<b>WEIGHT</b>	16 oz
<b>ELECTRICAL</b>	
Voltage input range	12.5-18 Vdc
Current	500 mA max
Audio input impedance	600 ohms
Input isolation	Better than 80db
<b>AUDIO OUTPUT</b>	
Headphones	50 mW Continuous RMS power into 150 ohms
Cabin speaker	2.5 W Continuous RMS power into 4 ohms
<b>AUDIO INPUTS</b>	
Switched	COM 1, COM 2, NAV 1, NAV 2, MKR
Un-switched	4 (examples ADF, DME, Autopilot Alerts)

Val Avionics Ltd  
AP 100 Audio Panel  
Installation and Operator's Manual

## 1.5 EQUIPMENT SUPPLIED

**Table 2 Equipment Supplied**

QTY	DESCRIPTION	PART NUMBER
1	AP 100 AUDIO PANEL	0800100
1	MOUNTING TRAY	0511002
1	INSTALLATION KIT	0650100

## 1.6 EQUIPMENT REQUIRED BUT NOT SUPPLIED

**Table 3 Equipment Not Supplied**

QTY	DESCRIPTION	PART NUMBER
1	Interconnect Wire Harness	VPN 0751005 or field fabricated
1	Microphone Jacks	Switchcraft P/N S12B (Ref VPN 550018)
1	Headphone Jacks	Switchcraft P/N 11 (Ref VPN 550017)
1	Circuit Breaker 2 amp	Potter & Brumsfield W58-2 (Ref VPN 0331005)
1	Aircraft Cabin Speaker	Ref aircraft parts manual for specific part number
1	Contact Crimping Tool w/ Positioning Tool	AMP P/N 601966-1 AMP P/N 601699-5

## 1.7 LICENSE REQUIREMENTS

None

## **2 SECTION II - INSTALLATION**

### **2.1 GENERAL INFORMATION**

#### **2.1.1 Scope**

This section of the manual will provide the needed information to successfully complete the installation of your new AP 100 Audio Panel. Please read this section completely before proceeding with the installation process. Although the AP 100 installation procedures are designed with the do-it-yourselfer in mind, we at Val Avionics strongly suggest that you seek the advice of a qualified avionics installation facility before beginning this or any other installation project. Qualified Avionics installation technicians can offer good advice as to time-tested installation practices and techniques that can save you many hours of time and frustration.

### **2.2 UNPACKING AND INSPECTION**

Use care when unpacking the equipment. Inspect the unit and supplied parts for visual signs of damage during shipment. Examine the unit for loose screws, dents, broken buttons and other signs of damage that may have occurred during shipment. Verify the contents of the container with the list in section 1.5. If any damaged or missing parts are discovered during the inspection save the shipping material and contact the freight carrier to file a claim. If it is suspected that parts were omitted from the container please feel free to contact Val Avionics to acquire the missing items.

### **2.3 EQUIPMENT INSTALLATION PROCEDURES**

#### **2.3.1 Cooling Requirements**

Forced air cooling is not required for the AP 100 audio Panel. However, when planning the location for mounting ensure adequate spacing from heat producing sources such as heating or defrosting ducts.

### **2.3.2 Mounting Requirements**

The AP 100 Mounting Tray (VPN 0511002) should be rigidly mounted in the avionics stack using the hardware provided in the installation kit. Ensure that the mounting location will provide easy access and a clear view of the equipment's front panel from the pilot's position. Ensure that the mounting position will provide adequate clearance between the unit and the associated wire harness and the aircraft controls. Bracing at the rear of the unit should be installed to ensure rigidity in the panel. Consult FAA Advisory Circular AC 43.13-2A for acceptable practices and techniques.

### **2.3.3 Wire Harness Fabrication**

Val Avionics recommends that a factory fabricated wire harness (VPN 0751005) be used for the installation of the AP 100 Audio Panel. Use of the factory fabricated wire harness will ensure proper operation of the Audio Panel, reduction in the occurrence of interfering audio signals and ground loops, greatly reduced installation time, and provide prolonged trouble-free performance of your new equipment. Contact Val Avionics or your local avionics distribution center for AP 100 Wire Harness ordering information.

Although strongly recommended, it is not required to use the factory fabricated wire harness when installing the AP 100 Audio Panel. A wiring harness can be fabricated in the field. Refer to appendix B of this manual for a complete wiring diagram. All wires must be 22 AWG MIL-SPEC, unless otherwise noted in accordance with current regulations. Two and three conductor shielded MIL-C-27500 or equivalent wire must be used where indicated. Use AMP Contact Crimping Tool (AMP P/N 601966-1) with Positioning Tool (AMP P/N 601699-5) or equivalent to ensure good quality contacts. Refer to FAA Advisory Circular AC 43.13-2A for acceptable practices and techniques.

### **2.3.4 Audio Panel Installation**

Carefully insert the Audio Panel into the mounting tray. The unit should slide into the tray freely without binding. Approximately 3/8" before complete insertion into the tray check for alignment of the DB25 connector on the unit and the mating DB25 connector at the back of the tray. Using a 7/64" allen wrench access the locking pawl screw located at the top center access hole on the face of the unit. Rotate the screw clockwise to draw the Audio Panel fully into the mounting tray. There will be a .020" gap between the back surface of the unit's faceplate and the front edge of the mounting tray when the unit is fully seated.

## 2.4 POST INSTALLATION CHECK

### 2.4.1 Operational Check

- Switch on Aircraft Master and Avionics Master as appropriate.
- Power on the unit by pressing the 'PWR' switch. The blue LED should illuminate.
- Plug headset into jackset
- Select COM 1 by pressing the 'COM 1' XMT SEL' switch. The green LED will illuminate. If the LED is flashing, stop testing and troubleshoot the microphone PTT installation. A flashing indicator in the COM select button indicates that the key line is grounded.
- Verify proper transmit and receive operation on the NO. 1 COM. Note that the LED flashes during the transmit function.
- Select COM 2 by pressing the 'COM 2' XMT SEL' switch. The green LED will illuminate. Note that the LED flashes during the transmit function.
- Press the 'BOTH' button and verify that COM 1 and COM 2 receive audios can be heard. Note that the button stays in and the LED illuminates.
- Verify proper operation of the NAV 1 and NAV 2 receiver sources by selection them using the 'NAV 1' and 'NAV 2' buttons. Note that the button for the receiver source stays in and the LED illuminates to show which source is in use.
- Push in the 'SPKR' button to activate the cabin speaker and verify that the selected audio source can be heard over the cabin speaker. Verify that the speaker is muted when a transmitter is keyed.
- Press the 'MKR MUTE' button and verify that the marker audio is muted and that the LED indicator flashes for approximately 20 seconds. The LED indicator will then go steady again and the marker audio can be heard.
- Verify that the AP 100 Audio Panel does not adversely affect any other aircraft system by systematically switching the unit on and off while monitoring the other avionics and electrical equipment on the aircraft.

### 2.4.2 Final Inspection

Verify that the wiring is bundled away from all controls and that no part of the installation interferes with the movement of the aircraft controls. Move all of the aircraft controls through their full range of movement while visually verifying that the installation does not mechanically interfere with the control movement. Verify that the wiring harnesses are properly secured to the aircraft structure in accordance with accepted practices as described in AC 43.13 and that adequate strain relief and service loops have been provided. Ensure that there are no kinks or sharp bends in the wire harnesses. Verify that the wire bundles are not exposed to any sharp or abrasive surfaces.

Val Avionics Ltd  
AP 100 Audio Panel  
Installation and Operator's Manual

Complete log book entries, FAA form 337, weight and balance computations and other documentations as required.

## **2.5 LIMITATIONS**

There are no known limitations to the operation of the AP 100 Audio Panel. Instructions for Continued Airworthiness and Return to Service Instructions can be found in Appendix C.

## 3 SECTION III - OPERATION

### 3.1 GENERAL INFORMATION

#### 3.1.1 Scope

This section will provide detailed operating instructions for your new AP 100 Audio Panel. Please read this section completely to become familiar with all of the features of the audio management system.



Figure 1 Unit Controls

#### 3.1.2 Transmit Selection

With the unit turned on, the pilot can select to transmit on COM 1 or COM 2 by depressing the corresponding selector button. The selected transceiver is indicated by an illuminated LED. Received audio from the selected transceiver is automatically switched to the headphones. While the transmit key is depressed the LED indicator will flash alerting the pilot that the selected transmitter is active. Only one transmitter can be selected at any time. With the unit turned off the pilot's microphone and head set are automatically connected to COM 1.

#### 3.1.3 Audio Selection

Received audio from both COM 1 and COM 2 can be routed to the headphones as desired by activating the BOTH switch. When both audios are selected an LED annunciation will illuminate. NAV 1 and NAV 2 audios can be switched to the headphone using the NAV 1 and NAV 2 selector switching. These selections are also indicated by LED annunciation. All of the selected audios can be switched to the cabin speaker with the SPKR select switch. An LED annunciation will indicate this selection.

If the audio from an external marker beacon receiver is connected to the AP 100 the received audio will be routed to the headphones without any action required by the flight

Val Avionics Ltd  
AP 100 Audio Panel  
Installation and Operator's Manual

crew. Muting for the external marker beacon receiver audio is provided by the MKR switch. A steady LED annunciator for the MKR switch indicates that marker beacon received audio, if present, will be heard in the headphones and over the cabin speaker if the SPKR switch is selected. The pilot may mute the marker audio by depressing the MKR select switch. Doing so will mute the incoming marker audio for approximately 20 seconds. While the marker audio is muted the MKR LED annunciator will flash.

Four un-switched audio inputs are provided at the rear connector for such audio inputs as DME, ADF, Auto Pilot alerts or any other audio source which would commonly be routed to the aircraft headphone and cabin speaker systems. These audios are not controlled by any of the selector switches on the AP 100, therefore audio levels for these devices will be controlled on each respective unit.



**Figure 2 Unit Controls**

## 4 SECTION IV - WARRANTY AND SERVICE

### 4.1 WARRANTY

The equipment delivered with this Standard Factory Warranty is manufactured by Val Avionics, Ltd. and is guaranteed against defective materials and workmanship for one year from date of original retail purchase. Any unit found to be defective due to material and workmanship during the warranty period will be repaired or replaced at the sole discretion of Val Avionics.

Val Avionics, LTD's liability under this warranty is limited to servicing, repairing or adjusting any equipment returned prepaid to the Val Avionics' factory by express written or verbal authorization for that purpose and to repair or replace defective parts thereof.

If, upon examination, it is determined that a malfunction has been caused by misuse of the equipment, installation or operation not in accordance with factory instructions, accident or negligent damage, alterations of any manner, and repair by other than the factory, the repairs will not be covered under the warranty. In such cases, an estimate will be submitted for approval before repair is initiated. In most cases, Val avionics, Ltd. will provide 72-hour turn around on its warranty and repair service. We recommend that contact be made with the FACTORY CUSTOMER SERVICE DEPARTMENT prior to any unit return and obtain RETURN AUTHORIZATION AND INSTRUCTIONS. This will provide proper control and expedite service.

Val Avionics, Ltd. reserves the right of continuous product development without obligation to install changes in previously manufactured products.

Installation of Val Avionics, Ltd. products must conform to methods acceptable by the Federal Aviation Administration as described in the appropriate Federal Aviation Regulations (FAR's) and Advisory Circulars (AC's).

To ensure proper warranty registration, type or print clearly the application information on the enclosed PRODUCTS WARRANTY REGISTRATION FORM and return to Val Avionics, Ltd.

Val Avionics Ltd  
AP 100 Audio Panel  
Installation and Operator's Manual

## 4.2 SERVICE

Repair service for the AP 100 Audio Panel is available at our manufacturing facility. Units in need of servicing should be returned prepaid to Val Avionics Ltd at the following addresses.

**If you are shipping by the US Postal Service** address To:

Val Avionics  
P.O. Box 13025  
Salem, OR 97309

**If you are shipping by Fedex, UPS** or other shipping company, address To:

Val Avionics  
3280 25<sup>th</sup> ST SE  
Salem, OR 97302

## 5 Appendix A – INSTALLATION DRAWINGS AND CONNECTOR LAYOUT

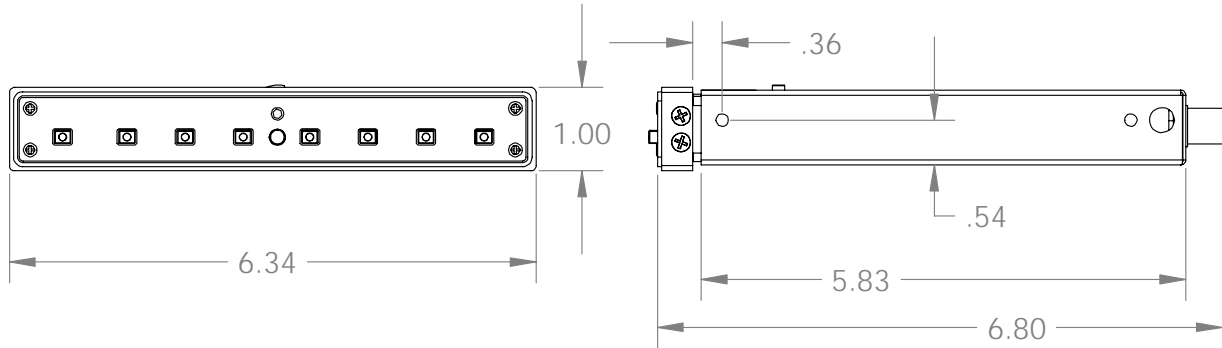

**Figure 3 Physical Dimensions**

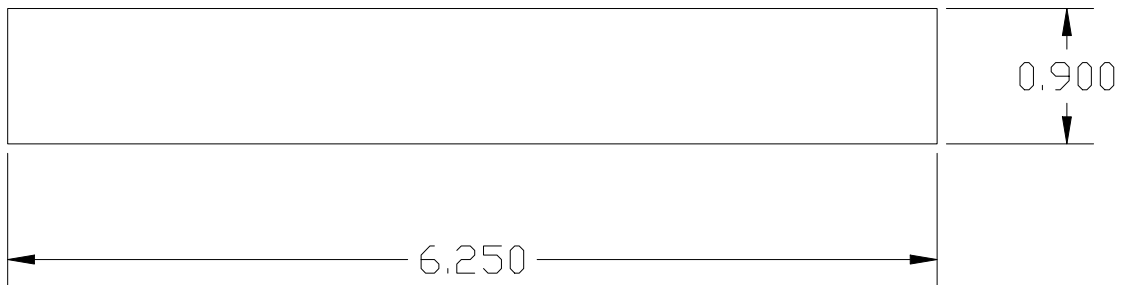

**Figure 4 Panel Cut Out**

Val Avionics Ltd  
 AP 100 Audio Panel  
 Installation and Operator's Manual

## 6 Appendix B – WIRING DIAGRAMS

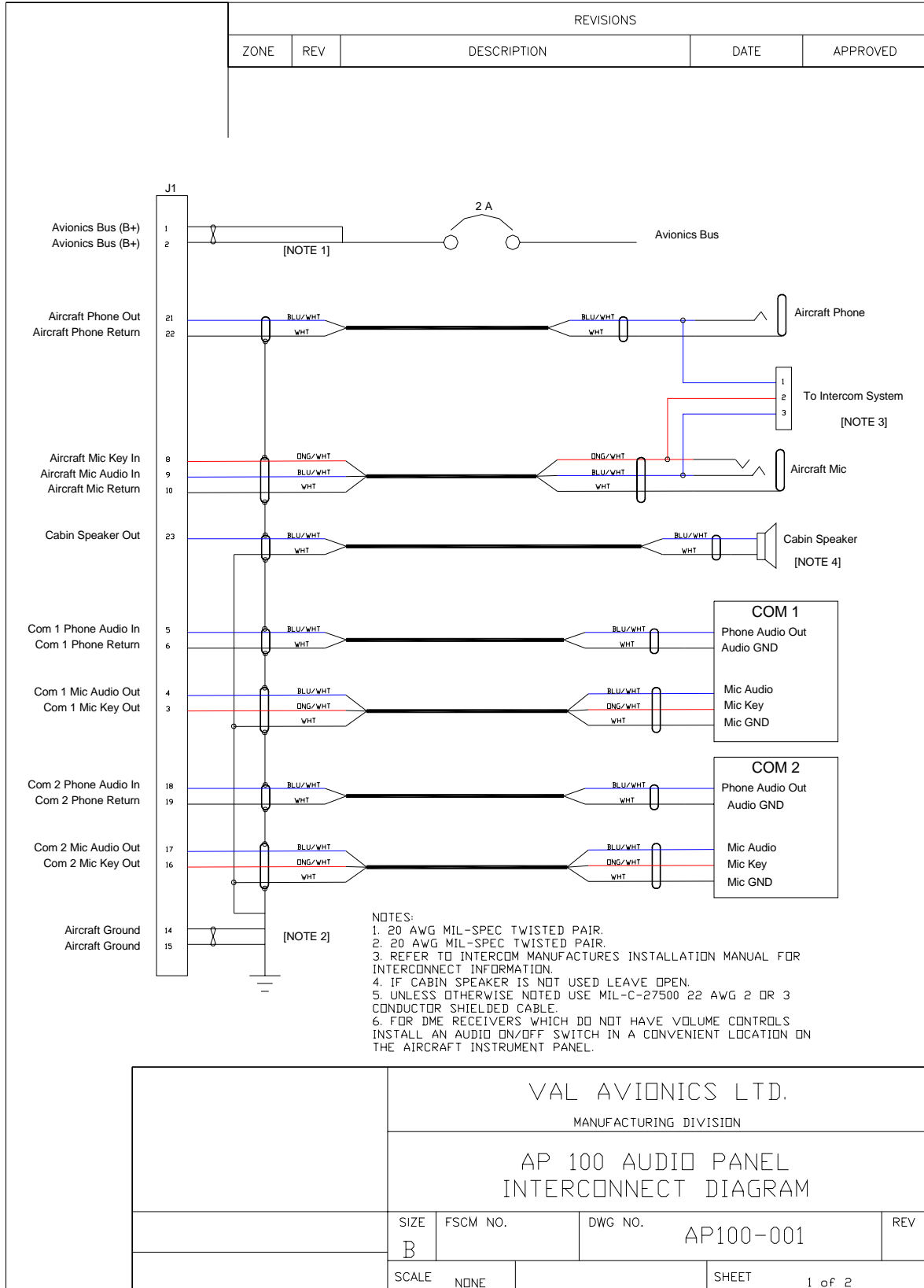

Val Avionics Ltd  
 AP 100 Audio Panel  
 Installation and Operator's Manual

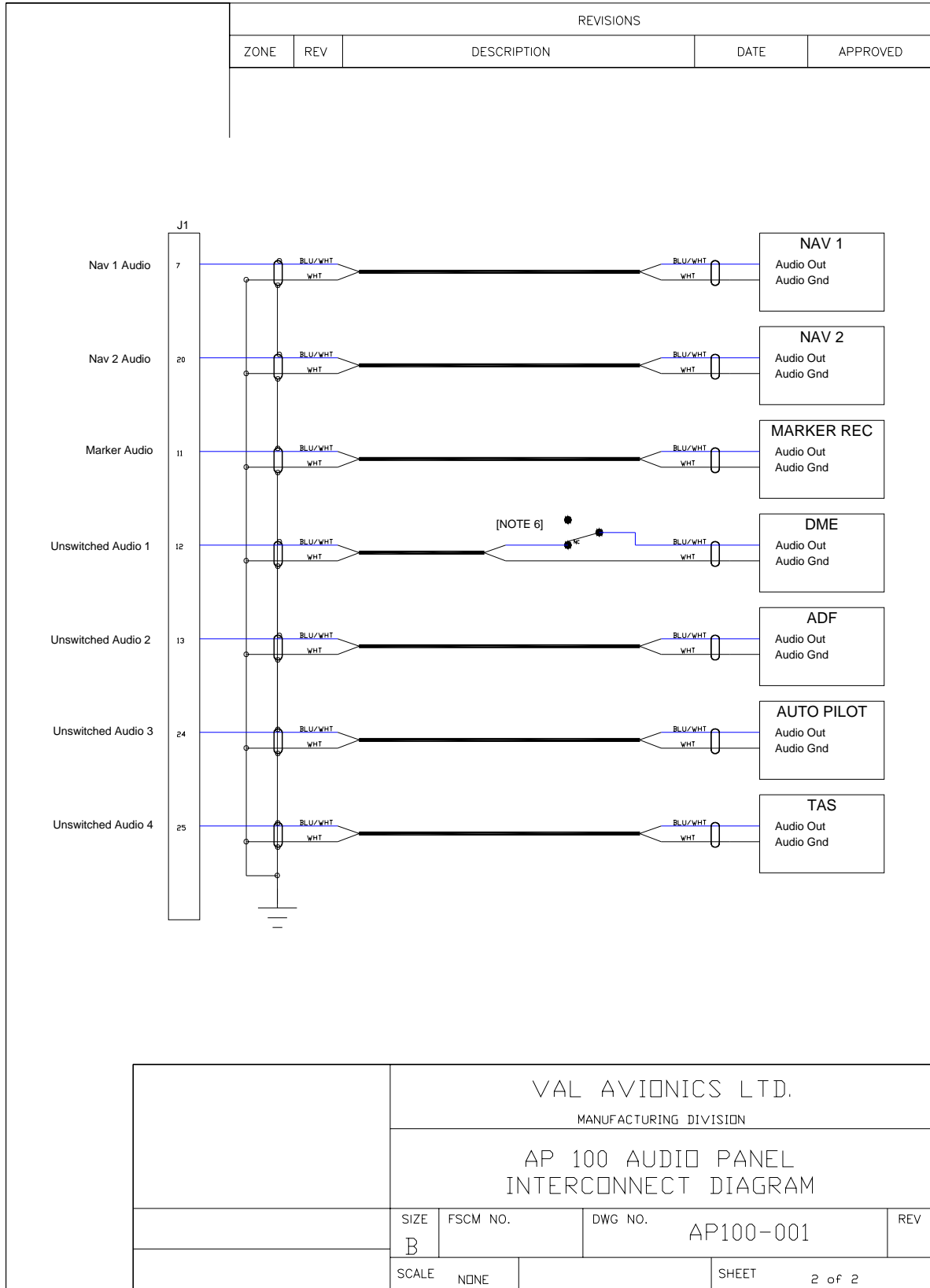

VAL AVIONICS LTD.		MANUFACTURING DIVISION		
AP 100 AUDIO PANEL INTERCONNECT DIAGRAM				
SIZE	FSCM NO.	DWG NO.	REV	
B		AP100-001		
SCALE	NONE	SHEET	2 of 2	

## **7 Appendix C – INSTRUCTIONS FOR CONTINUED AIRWORTHINESS**

### **7.1 MAINTENANCE INSTRUCTIONS**

Maintenance of the AP 100 is on condition only. No periodic maintenance is required. If unit is removed for service, upon re-installation perform Post Installation check as described in section 2.4 of this manual.